

PUMP CONTROLLER

EM30

0,4kW – 11kW

*Safety instructions Installation
& operating manual*

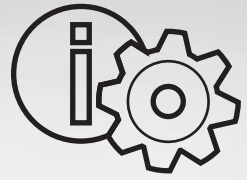

Eura Drives GmbH

1,50 bar

AUTO : 42Hz, 007,9A

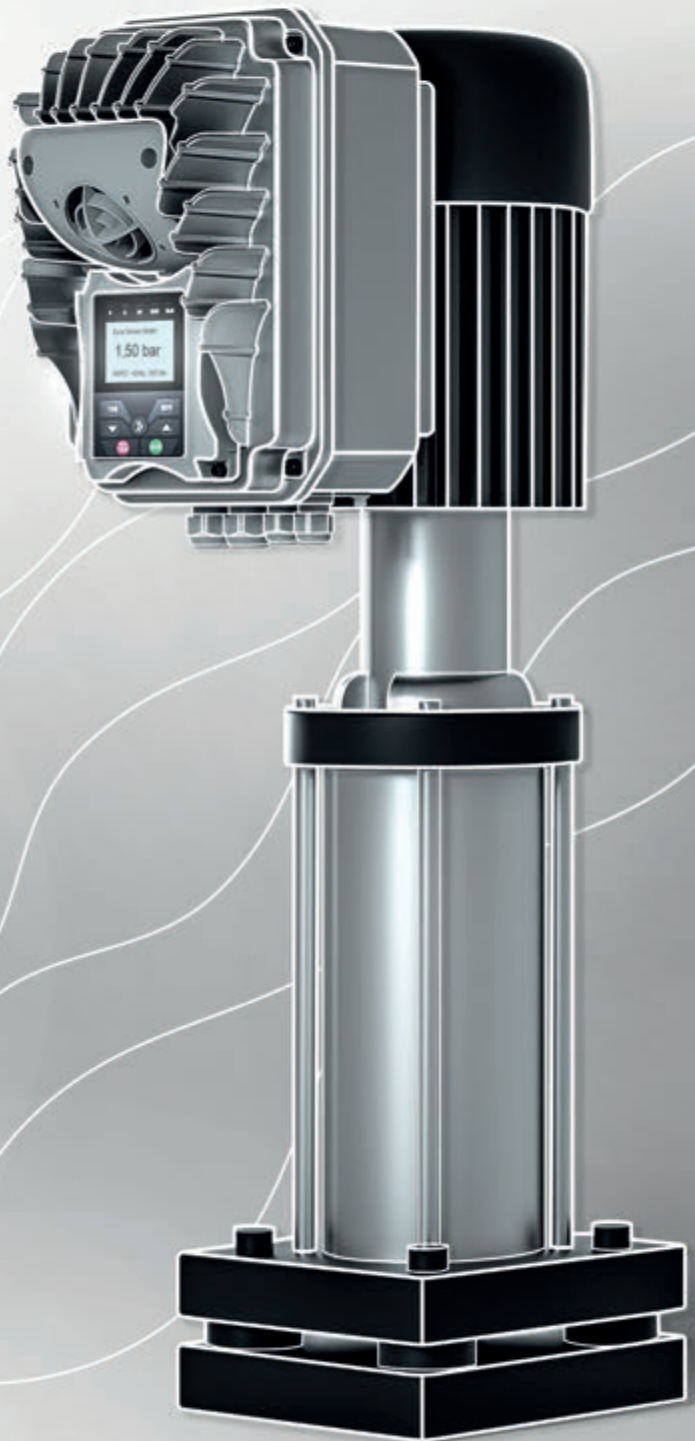

EURa[®]
DRIVES

| www.euradrives.eu |

ENGLISH

Software Version 1.03
© 2017 EURA Drives GmbH

Instruction manual: **Pressure**
Type: MARI-EM30

Pump controller :
S-No.: _____

System controller for pumps
with frequency inverter

EM30 Software Version 1.03 (18.x) Stand 23.02.2017

Execution: **pressure controller**
level controller
temperature controller
vacuum controller

content	page
1. Safety Precautions	3
2. General / Mode of Operation	4
3. Installation and Mounting	4
4. Wiring and Connections	5
5. panel Description	6
6. Basic Settings	8
7. Pump controller Menu	9
8. Pump Menu Chain	11
9. Trip history monitor /Troubleshooting	12
10. Expert mode	13
11. Operating mode Multi	18
12. Operating mode Inverter	16
13. Adjust motor characteristic	17
14. Clear fault memory / Starts	18
15. LED status	18
16. Terminal plan / transducer connection / mains connection	19
16. customer settings	20

1. Safety Precautions

Before installing and commissioning of the frequency converter controller, please read the product manual carefully and observe all warnings and safety instructions. Keep this manual is always easily accessible in the vicinity of the frequency converter controller.

Definition of Information



Warning !

Disregarding the safety severe to fatal injuries can occur or considerable material damage!



Caution!

Failure to follow these instructions severe to fatal injuries can occur or considerable material damage!



Notice!

Failure to follow these instructions may result in malfunction of the system!

Warning!

The drive controller contains dangerous voltages and controls potentially dangerous rotating mechanical parts. The installation, commissioning and maintenance of this equipment should be performed only by qualified personnel who are familiar with the operation. The installation, commissioning and maintenance of this equipment should be performed only by qualified personnel who are familiar with the operation.

Do you have particular caution if the automatic restart is activated. To avoid injury by possibly unintentional restart of the drive controller after a power failure, turn off the automatic restart in case of doubt. When repairing or servicing this equipment, make sure that the system can not be switched on by others again! **The frequency controller have DC link capacitors, which carry hazardous voltage even after the mains supply is switched off. Therefore, always wait after switching off the mains voltage for at least 5 minutes before working on the machine or turn on the unit again.** It is important to ensure that no live parts are touched when power is applied or the intermediate circuit capacitors are charged.

Do not work on the wiring and check any signals when power is applied.

The Inverter - Regulator has a leakage current.

Ground the frequency controller on the connections provided.

The customer-supplied GFCI should be in the Inverter - Regulator **universal current sensitive / selective RCD (FI) - Circuit breaker type: B, B + be with rated current 300mA.**

Caution! An RCD (FI) - switch can not work sometimes in certain plants (eg long cable).

It is recommended that the frequency converter - controllers separately fused.

Make sure that the input voltage of the registered on the nameplate voltage.

Caution!

All frequency controllers are tested for dielectric strength and insulation resistance. Before the insulation measurement in the pump station, for example within the scope of the inspection frequency controller must be disconnected!

It is strongly recommended that all electrical equipment conforms to the National Electrical Codes and local regulations.

Factors such as high temperatures, high humidity as well as dust, dirt and corrosive gases. The installation should be a well-ventilated, not exposed to direct sunlight place.

Put them no mains voltage to the transducer terminals or to the control terminals. Enter the operating signals Hand/0/Auto via the selector switch on or about the driving of external contacts and not by switching on and off of a line or motor contactor.

It is strongly recommended that all electrical equipment conforms to the National Electrical Codes and local regulations. Only qualified personnel should perform installation, alignment and maintenance. The manufacturer reserves the right to alter the technical data in order to make improvements or update information.

As these provisions are handled differently, the user must observe the respectively valid for Him requirements. The manufacturer can not release you from the obligation to comply with the latest safety standards the user..

Notice!

The technical data and descriptions in this guide are correct to the best knowledge and belief. Technical improvements have been continuously carried out - that's why the manufacturer reserves the right, without prior notice to carry out such changes.

The manufacturer can not be held liable for errors in the manual.

Warranty is within Germany and within the

incorporated statutory warranty period and applies only to the product itself and not for any consequential loss or damage or costs associated with the occurrence of a Warranty claim arise at other plants or plant parts. The operator shall, in each case to ensure that a failure or defect in the product can not lead to further damage.

2. Construction of a pressure control system

Non-return valve preventer is imperative and must be in the pressure behind the Pump will be installed! The expansion tank is to be fitted if required.

1 Flow direction	5 Non-return valve
2 Controller	6 Pressure Transducer
3 Motor	7 Pressure vessel
4 Pump	

Examples:

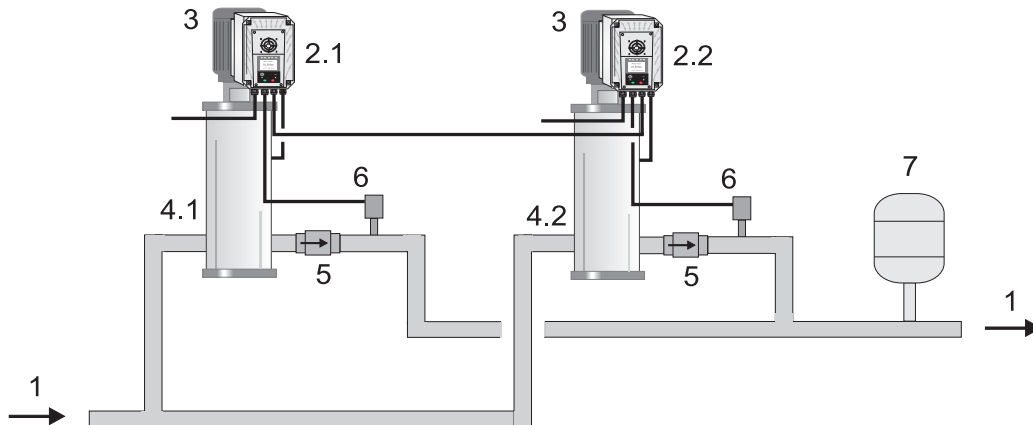
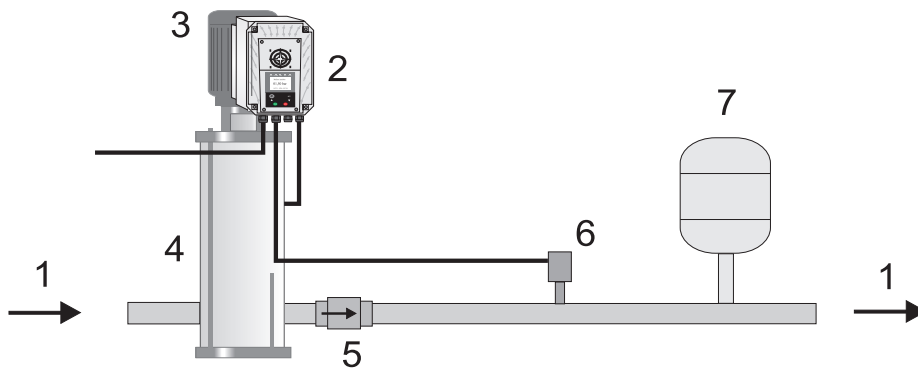

Note for the operation of the system with Pressure vessel!
 If the plant is operated with a pressure vessel, the vessel must be pre-pressed in normally state.
 The pre-squeezing pressure should be checked regularly. The amount of pre-squeezing pressure is: Start pressure bar minus 0.50.

3. Installation and Mounting



Caution!

Environmental conditions such as high temperatures, high humidity should be avoided as well as dust, dirt and corrosive gases. The installation should be a well-ventilated and not exposed to direct sunlight location. Because of convection, the frequency control during installation of at least Be installed 15 cm from side walls or other facilities.



Warning!

The allowable temperature range of +5 ° C to +30 ° C must not be under-or exceeded Do not install the Inverter controller near heat-radiating bodies

3.1 Mounting the EM30-MA Controller

The compact housing is constructed with an adapter in place of the terminal box using 4 holes. Mounting details: See manufacturer's data sheet MARI (EM30).

4. Wiring and Connections in Controller mode



Warning!

Make sure that the input voltage indicated on the product nameplate voltage. Be sure to supply voltage and terminal assignment note!



Caution!

Do not apply a voltage to the sensor - and control terminals. The pressure sensor used 0-10V or 4-20mA, are connected to the respective terminals! The respective pin assignment, refer to the diagram. Check the correct connection of power, sensor, and control lines.

4.1 Motor protection

The MARI-EM30 Inverter controller has a monitoring function for the motor current. This motor current is set via the controller menu. In addition, PTC thermistors are to monitor the temperature used. This monitoring is set via the controller menu..

4.2 Power supply: 230V or 400V 50 / 60Hz

Clamp	Function	Description
L1	Power Supply	L1 Phase
L2 (N)	look	L2 Phase (Neutral) See 16.Connection diagram MARI
L3	Type plate	L3 Phase
PE		PE Ground

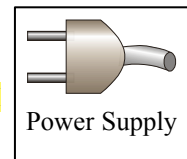

4.3 Port for the fault signal relay per inverter

Clamp	Function	Description
1 TC 1/2	Alarm relay	Alarm contact
2 TB 1/2	changer	Alarm contact
3 TA 1/2	230V 2 A limit	Alarm contact

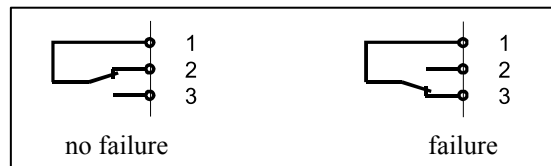

4.4 Port for the external inputs

Clamp	Function	Description
CM	Common	Ext. Common
DI1	Ext. On / Off	Ext. Input 1
DI2	Ext. low water on	Ext. Input 2
DI3	Chain	Ext. Input 3
CM	PTC	+ Motor
DI5	PTC	- Motor

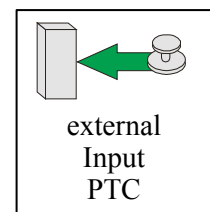

4.5 Port for the transducer 0-10V/ 4-20mA

Clamp	Function	Description
P24	24VDC +	Transducer +
CM+GND	24VDC -	Bridge / Transducer -
A11	Signal 0-10V	Sensor Signal V
A12	Signal 4-20mA	Transducer Signal mA

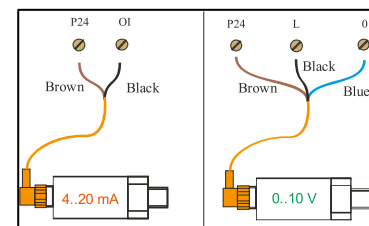

4.6 Connection for the motor / pump 3x230V or 3x400V 50 / 60Hz

Clamp	Function	Description
U	3 phase motor	U
V	look	V
W	wiring diagram	W

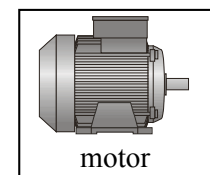







When disturbances to the notes under 9.2 Troubleshooting note!

5. Panel Description MARI

Control panel with LCD display for parameters and operating data:



-  - stop engine / reset failure
-  - start the motor
-  - Changing mode, change parameter location
-   - Browse parameters change values
-  - store values / Clear Memory
-  - base Settings



5.1 MARI-EM30 display:

Active main display

After initialisation is complete, the display will return:

Status indicators during controller mode

Display manual mode (HAND)

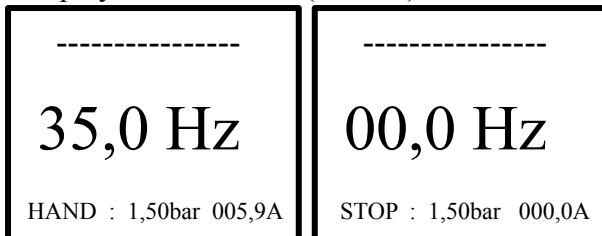

Display in automatic mode (AUTO)

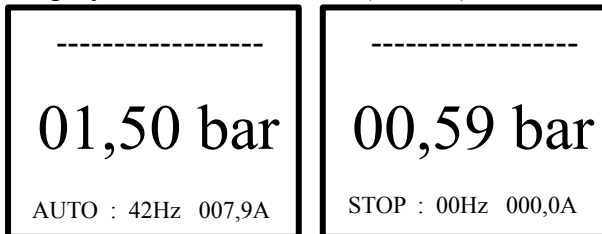

Display „Motor poti“

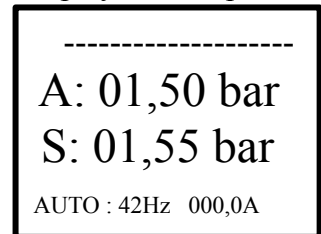

Display with analog Guardian

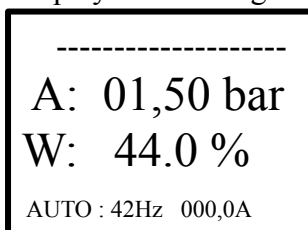

5.2 MARI-EM30 Hand / Auto Change:

Operate system with manual or automatic mode.

Select 5.2.1 Manual operation

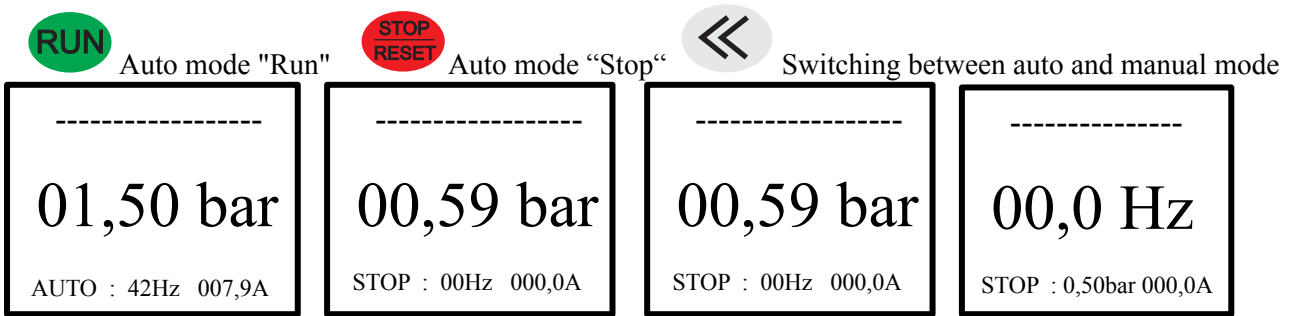

5.2.2 Select Automatic mode

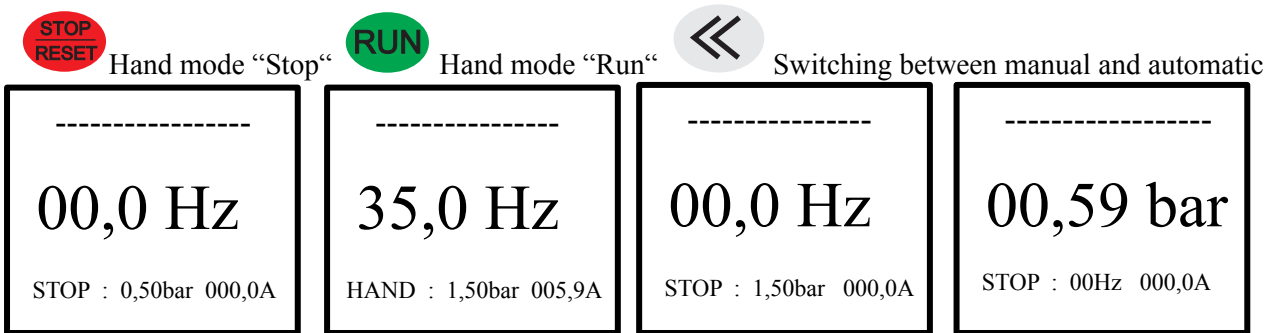

5.3 MARI manual / auto mode with "Motor poti"

Setting values in manual mode or automatic mode with "Motor potentiometer".
 A : actual "pressure", S : setpoint "pressure"

Attention ! "Motor poti" is possible only with single units!

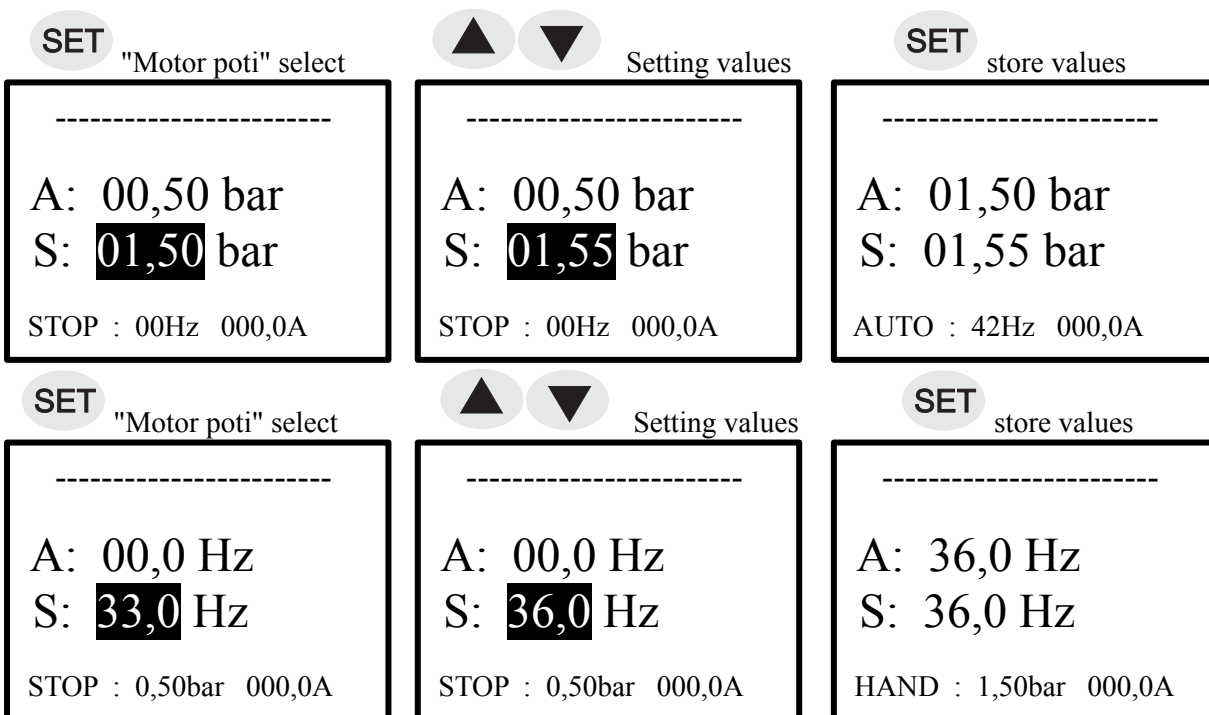

6. Basic Menu

6.1 Setting the basic

CODE Input!

Attention ! Only in stop possible!



Press "Stop" button.



"FUN" button for 10 seconds. hold

The basic menu is displayed.



-----Basic--settings-----	
Language	: 1
Operating mode	: 1
Unit	: 0
Range	: 1000
Offset	: 0
Sensor V/mA	: 1
Control type	: 1
Standby type	: 0
testing phase	: 1
PTC	: 1
keypad	: 0
Quickstart	: 0
Light	: 99
Lock on/ off	: 0
Characteristics	: 2
analog Guardian	: 0

-----Basic--settings-----	
Language	: 1
Operating mode	: 1
Unit	: 0
Range	: 1000
Offset	: 0
Sensor V/mA	: 1
Control type	: 1
Standby type	: 0
testing phase	: 1
PTC	: 1
keypad	: 0
Quickstart	: 0
Light	: 99
Lock on/ off	: 0
Characteristics	: 2
analog Guardian	: 0

-----Basic--settings-----	
Language	: 2
Operating mode	: 1
Unit	: 0
Range	: 1000
Offset	: 0
Sensor V/mA	: 1
Control type	: 1
Standby type	: 0
testing phase	: 1
PTC	: 1
keypad	: 0
Quickstart	: 0
Light	: 99
Lock on/ off	: 0
Characteristics	: 2
analog Guardian	: 0

-----Basic--settings-----	
Language	: 2
Operating mode	: 1
Unit	: 0
Range	: 1000
Offset	: 0
Sensor V/mA	: 1
Control type	: 1
Standby type	: 0
testing phase	: 1
PTC	: 1
keypad	: 0
Quickstart	: 0
Light	: 99
Lock on/ off	: 0
Characteristics	: 2
analog Guardian	: 0



"FUN" button for 2 sec. And hold to exit the base.

6.2 Setting the basic parameters

Set the menu language

Language :1 - 1 = D (German), 2 = E (English)

Set the desired operating mode.

Operating mode :1 - 1 = Pump controller, 2 = chain 3 = Multi, 4 = inverter

Enter the unit for the measurement range.

Unit :0 - 0 = bar,

Enter the measuring range of the sensor.

Range :1000 - 0 - 9999 , (1000 = 10bar)

Enter the if necessary the sensor offset.

Offset : 0 - 0 - 9999

Select the input signal for the sensor. Data: See nameplate sensor.

This function lets you choose the option signal between 0-10V and 4-20mA. (Connection see special wiring diagram)

Sensor V/ mA :1 - 1 = V, 2 = mA

Enter the function of the PID control. (TO filling or emptying)

Control type :1 - 1 = positive, 0 = negative

Enter the function for standby. (Stop or basic speed)

Standby type :0 - 0 = stop, 1 = base speed with cutoff

Enter the test phase for the zero flow cut-off at the slave.

testing phase : 0 - 0 = off / 1 = on

If necessary, select the PTC function for engine monitoring.

PTC :1 - 1 = off / 2 = on

Enter the keypad function for safe operation.

If the set value is greater than 0, the drive is stopped when the keypad is disconnected (safe operation).

Keypad :0 - 0 - 30s

Enter to shorten the charging time at "power on" the Quick Start.

Quickstart :0 - 0 = off / 1 = on

Enter the time for the display backlight. 0 = off; 100 = permanent light

Light :99 - 0 - 100

If necessary, select the Lock function for the parameter. **The code is then "174".**

In Block "1", the motor potentiometer function is still active. In Block "2" is all blocked.

Lock / Unlock : 0 - 0 = OFF / 1 = a single / 2 = an all

Set the characteristic for the motor. When "6" is selected, the motor data must be entered.

Detailed description on page 19 "Setting the engine characteristic"

Characteristics :2 - 2 = V/Hz- Asynchronous motor, 6 = PM- Synchronous motor

Set the analog Guardian

analog Guardian :0 - 0 = off, 1= low water 2= dry run



7. Pump controller Menu (1)

CODE Input!

Attention ! Only in stop possible!

STOP RESET Press "Stop" button. **FUN** "FUN" button for 10 seconds. hold

▲ ▼ SET ▲ ▼ SET

-----Basic--settings----- Language : 2 Operating mode : 2	-----Basic--settings----- Language : 2 Operating mode : 2	-----Basic--settings----- Language : 2 Operating mode : 1	-----Basic--settings----- Language : 2 Operating mode : 1
-----------------------------------------------------------------	-----------------------------------------------------------------	-----------------------------------------------------------------	-----------------------------------------------------------------

FUN "FUN" button for 2 sec. And hold to exit the base.

Status fault memory Status „Motor poti“ Status Main

Starts: 15 45° RH: 000 : 00 : 43 E011 , 45Hz, 10,5A, 00,15bar -- ERR 2 -- -- ERR 3 -- -- ERR 4 --	A: 01,50 bar S: 01,55 bar AUTO : 42Hz 000,0A	01,50 bar AUTO : 42Hz 007,9A
------------------------------------------------------------------------------------------------------------------	----------------------------------------------------	---------------------------------

Parameter menu

-----Controller--Parameter-----

- set point : 4,00
- start difference : 0,50
- testing phase : 90
- stop frequency : 35,0
- overrun time : 05,0
- starting delay : 05,0
- a value tolerance : 01,0
- minimum frequency : 25,0
- maximum frequency : 50,0
- hand frequency : 30,0
- Control monitor : 0
- deviation : 50
- guard time : 180
- external on / off : 1
- external alarm : 1
- autostart : 0
- autoreset : 0
- *rotating : 0
- accelerate : 02,0
- decelerate : 03,0
- rated current : 09,0
- analog Guardian over: 90 %
- analog Guardian on : 60 %
- analog Guardian off : 40 %

A: 01,50 bar
W: 44.0 %
AUTO : 42Hz 000,0A



Setting parameters using the example of set point

▲ ▼ SET ▲ ▼ (if necessary) <<

--Controller--Parameter-- set point : 4,00 Start difference : 0,50	--Controller--Parameter-- set point : 4,00 Start difference : 0,50	--Controller--Parameter-- set point : 4,00 Start difference : 0,50	--Controller--Parameter-- set point : 4,00 Start difference : 0,50
--------------------------------------------------------------------------	--------------------------------------------------------------------------	--------------------------------------------------------------------------	--------------------------------------------------------------------------

▲ ▼ SET

--Controller--Parameter-- set point : 4,60 Start difference : 0,50	--Controller--Parameter-- set point : 4,60 Start difference : 0,50
--------------------------------------------------------------------------	--------------------------------------------------------------------------

7.1 Controller Setting Parameters

Enter the set point, at which the system should operate.

set point :04,00bar - 0,01bar - xx,xx bar

Enter the starting difference, with which the system will work.

Start difference :00,50bar - 0,01bar - xx,xx bar

Enter the verification phase for zero amounts shutdown a. Recommendation: 50%. See also "zero flow cutoff"

testing phase :90% - 1% - 200% = 0,1- 2,00bar absolute

Enter the global stop frequency for zero amounts shutdown.

stop frequency :35Hz - 1Hz - 200Hz

Enter the overrun time of the follow-up time for zero amounts shutdown.

overrun time :5s - 1s - 99s

Enter the time of Starting delay for the restart after "Standby"

starting delay :5s - 1s - 99s

Enter the control tolerance for the PID - a regulation.

a value tolerance :1% - 1% - 10%

Enter the minimum frequency of the pump. This feature gives you the option to enter the minimum frequency of the pump for operation. This possibility of adjusting the pump speed can be limited.

minimum frequency :25Hz - 1Hz - 200Hz

Enter the maximum frequency of the pump. This feature gives you the option to enter the maximum frequency of the pump for operation. This possibility of adjusting the pump speed can be limited.

maximum frequency :50Hz - 1Hz - 650Hz

Enter the hand frequency in Hz, at which the respective motor is to be made manually.

hand frequency :35Hz - 1Hz - 650Hz

Enter the water deficiency function. 1 = All Off, 2 = sensor monitoring a, 3 = electronic dry run protection, 4 = pressure monitoring in%, 5 = electronic dry run protection + pressure monitoring in%

Control monitor :1 - 1 - 6

1 = Control monitor is off, sensor monitoring is off, dry-running monitoring is Off

2 = Control monitor is off, sensor monitoring / dry running (<0.1 bar) (10s)

3 = Control monitor on electronic dry run protection (<0.5 bar) (20s)

4 = Control monitor on pressure is low in%. (1- 100%) (40s)

5 = Control monitor on electronic dry run protection (<0.5 bar) + pressure low in%. (1- 100%)

6 = Control monitor on electronic dry run protection (<0.5 bar) + pressure low in%. (1- 100%) inactive in Manuel mode

Enter the deviation in% for the pressure is low. This value monitors the actual pressure on deviation.

deviation :50% - 0- 100%

Enter the guard time delay until the pressure drop is switched off.

guard time :180s - 0- 999s

Specify the function for the digital input 1. Attention ! Automatic restart.

external on / off :0 - 1 = closer / 0 = opener

Specify the function for the digital input 2. Attention ! Restart only after reset.

external alarm :0 - 1 = closer / 0 = opener

Specify the function for the startup to "power on".

autostart :0 - 1 = on / 0 = off

Select the Reset to function. At fault is automatically tried calling **3 times in 20 minutes**, again.

Autoreset can only be selected together with Autostart!

auto-reset :0 - 1 = on / 0 = off

Enter the direction of rotation of the pump (in). Power phase does not matter!

rotating :0 - 0 = right / 1= left

Enter the Acceleration time of the pump (s). Recommendation: 1-3 seconds.

accelerate :03,0s - 0,01s - 99,9s / only manual operation

Enter the deceleration time of the pump (s). Recommendation: 2-10 seconds.

decelerate :05,0s - 0,01s - 99,9s / only manual operation

Enter the motor rated current of the pump (s). Data: See nameplate.

rated current :xxx,0A - 0,01A - 199,9A

Enter the values in% for monitoring.

This value monitors the second analog input for deviation. Attention ! No "Motor poti" function possible!

0 = analog Guardian is off

1 = analogue Guardian is on "low water" - automatic restart!

2 = analogue Guardian is on "dry run" - no automatic restart! (Reset)

analog Guardian over :90% - 0- 100% Warning !

analog Guardian on :60 % - 0- 100% pump on

analog Guardian off :40 % - 0- 100% pump off

8. Mode "chain" (2)

CODE Input!

Attention ! Only in stop possible!

STOP RESET Press "Stop" button. **FUN** "FUN" button for 10 seconds. hold

▲ ▼ SET ▲ ▼ SET

-----Basic--settings----- Language : 2 Operating mode : 1	-----Basic--settings----- Language : 2 Operating mode : 1	-----Basic--settings----- Language : 2 Operating mode : 2	-----Basic--settings----- Language : 2 Operating mode : 2
-----------------------------------------------------------------	-----------------------------------------------------------------	-----------------------------------------------------------------	-----------------------------------------------------------------

FUN "FUN" button for 2 sec. And hold to exit the base.

Status fault memory Status Main (Master) Status Main (Slave)

Starts: 15 45° RH: 000 : 00 : 43 01.50 0-1 4.0 3.8 M E011 , 45Hz, 10,5A, 00,15bar -- ERR 2 -- -- ERR 3 -- -- ERR 4 --	----- M 01,50 bar AUTO : 42Hz 007,9A	----- S 01,50 bar AUTO : 00Hz 000,0A
-----------------------------------------------------------------------------------------------------------------------------------------	---------------------------------------------------	---------------------------------------------------

Parameter chain menu

-----Chain--Parameter----- difference value : 0,50 changing time : 300 All other parameters are like controller operation

▲ ▼

Setting parameters using the example of set point

▲ ▼ SET ▲ ▼ << (if necessary)

--Controller--Parameter-- set point : 4,00 Start difference : 0,50	--Controller--Parameter-- set point : 4,00 Start difference : 0,50	--Controller--Parameter-- set point : 4,00 Start difference : 0,50	--Controller--Parameter-- set point : 4,00 Start difference : 0,50
--------------------------------------------------------------------------	--------------------------------------------------------------------------	--------------------------------------------------------------------------	--------------------------------------------------------------------------

▲ ▼ SET

--Controller--Parameter-- set point : 4,60 Start difference : 0,50	--Controller--Parameter-- set point : 4,60 Start difference : 0,50
--------------------------------------------------------------------------	--------------------------------------------------------------------------

8.1 Setting parameters chains

Enter the difference value for the master-slave operation.
difference value : 00,50bar - 0,01bar - 10,00bar

Enter the switching time for the master-slave exchange with chain operation.
changing time : 300min - 1min - 999min

All other parameters see controller operation!



9. Error Messages



9.1 Error messages Frequency EM30

The error "Er002" to "Er xxx" are error messages. The red LED lights. The alarm relay switches.
Display examples:

Error messages can be reset by pressing  "Stop" button reset.

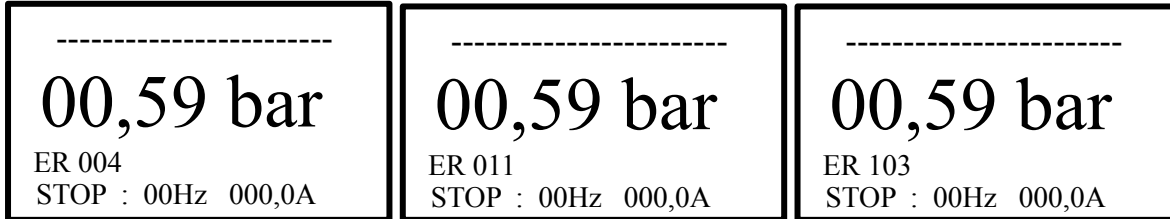

Inverter MA-FU

- error Er002 : Motor overload (O.C.)
Motor protection tripping. Reduce pump performance. Set motor protection!
- error Er003 : Over-voltage in the DC link with frequency (O.E.)
Generator operation, power surge, check check valves. Call service!
- error Er004 : Phase error power input (P.F1)
Phase failure. Check the fuses. Check mains voltage.
- error Er005 : Overload inverters (O.L1)
Check inverter power; reduce pump performance. Set the parameters!
- error Er006 : under-voltage (L.U.)
Grid voltage fault. Check fuses, check mains voltage.
- error Er007 : Inverter over temperature (O.H.)
Inverter is too hot. Reduce carrier frequency. Cooling defective??
- error Er008 : Overload inverters (O.L2)
Check inverter power; reduce pump performance. Set the parameters!
- error Er009 : External alarm (Err) !
External Alarm was triggered! Digital input 2 has been switched. Performing a reset!
- error Er011 : External fault ESP
Enter Wrong password on the frequency
- error Er012 : incorrect password frequency (ERR1)
Frequency defective. FU exchange. Call service!
- error Er013 : Errors motor parameters ERR2
Inverter set at the factory setting! Call service!
- error Er014 : Over current at standstill ERR3
Motor load at a standstill too high. Pump is blocked! Call service!
- error Er015 : Fault current measurement ERR4
Frequency defective. FU exchange. Call service!
- error Er016 : Motor overload (OC1)
Motor protection tripping. Reduce pump performance. Set motor protection!
- error Er017 : Phase error motor (PF0)
Motor phase interrupted. Check motor cable, check motor
- error Er018 : Broken wire analog signal (AErr)
Inverter set at the factory setting! Call service!
- error Er019 : Under load frequency (EP3)
Motor load too low during operation. Increase engine power! Pumps deliver too little?
- error Er020 : Under load frequency (EP)
Motor load too low during operation. Increase engine power! Pumps deliver too little?
- error Er021 : Under load frequency (EP2)
Motor load too low during operation. Increase engine power! Pumps deliver too little?
- error Er022 : Sleep mode nP
Inverter set at the factory setting! Call service!
- error Er023/44 : Inverter parameter incorrect (ERR5)
Inverter set at the factory setting! Call service!
- error Er026 : Ground fault in cable or motor or inverter (GP)
Check the wiring, the drive and the drive! Call service!
- error Er032 : Incorrect inverter parameters (EPCE)
Set inverter in factory setting! Call service!
- error Er035 : Error PTC tripping (O.H1)
The PTC thermistor has tripped. Reduce engine power. Improve cooling.
- error Er045 : Communication error with the frequency inverter (CE)
ModBus address wrong; ModBus connection faulty. Check connection or address?
- error Er053 : Communication error with the drive to the control panel (IP66 / EM30)
F930 is not set correctly. Setting the FU check Check keypad!

error Er072 : Motor overload (O.C.2)
 Motor protection tripping. Reduce pump performance. Set motor protection!
 error Er103 : Error running dry / sensor error electronically; Pressure less than 0.1 bar
 The dry-run protection / Transducer error triggered .. Water supply / Transducer check!
 error Er104 : Error analogous dry run;
 The analogue dry-running protection / sensor error has triggered. Check water supply / Transducer!
 error Er105 : Error analog value "limit"
 The analog limit of the value has triggered. Check water level / Transducer!
 error Er107 : Error pressure is low
 The internal pressure deficiency protection has tripped. Check pressure is low setting or water supply!
 error Er108 : Error dry run electronically; Pressure less than 0.5 bar
 The dry-running protection has triggered. Check water supply!
 error Er130 : Error chain
 The chain fault triggered. Check wiring and setting of chain operation!
 Fehler Er190 : Software error
 Call service!

9.2 Troubleshooting

The displays is dark

Mains voltage is present and turned on? If one or more fuses blown?

Plant does not start

The controller is not in operation! Press the "RUN" or switch between "manual" or "automatic"!

If properly closed when operating via the external input cable?

Plant does not start although the "RUN" shows.

Transducer not connected? (Message: "Sensor error")

The actual pressure is reached or over inflation pressure? The starting pressure is not set or too small?

Pump does not stop

If the set pressure is set too high (pumps create the pressure does not)? Is the pipeline of investment not vented properly? Non-return valve incorporated in the pressure line upstream of the sensor?

Zero flow cutoff is not set correctly? ***See: switch-off frequency, testing phase, switch-off delay!***

If the back-flow preventer leaking? In short rigid pipes, expansion vessel into the pressure line downstream of the back-flow preventer installed (pre-charge pressure check: starting pressure - 0.5 bar)!

Pressure indicator does not indicate the actual pressure

Pressure sensor type does not match the pressure sensor used (eg 10 bar - Sensor; 25 bar - sensor)?

Sensor or sensor plug is wet? Sensor cable is broken or connected incorrectly?

The control is too warm

Check ambient temperature! If necessary, provide cooling! Reduce carrier frequency!

Display shows no data and pump does not start

Connected pumps have the "power" switch on already ground fault.

Check frequency without pumps connected to function

10. Expert mode

10.1 switch-off frequency.

The switch-off frequency is the lowest operating frequency in the pressure control. If the switch-off frequency achieved waiting the pressure regulator the switch-off before the particular pump into "standby" position.

The switch-off frequency should be adjusted so that just no longer promotes the respective pump.

The delay time should be set so that does not get the pump in this operating point to vibrate.

This feature supports the zero flow cutoff.

10.2 zero flow shut-off

The zero flow shut-off ensures safe shutdown output "0".

The zero flow cutoff requires when setting some experience and detailed knowledge of the operation of the controller.

If the system with the factory setting of zero flow cutoff does not operate satisfactorily, please contact your dealer or the manufacturer.

The **test phase:** 1 - 99% **50%** Recommendation: 50%.

manipulates the desired pressure while the pump is operating to constantly check whether it delivers.

The larger the test phase, the safer switches on the pump when pumping "0".



To adjust the system with test phase and cutoff expertise is required!

Notice!

END Chan and Controller Menu

11. Operating mode "Multi"(3)

CODE Input!

Attention ! Only in stop possible!



Press "Stop" button.



"FUN" button for 10 seconds. hold

▲ ▼	SET	▲ ▼	SET
<p>-----Basic--settings-----</p> <p>Language : 2</p> <p>Operating mode : 1</p>	<p>-----Basic--settings-----</p> <p>Language : 2</p> <p>Operating mode : 1</p>	<p>-----Basic--settings-----</p> <p>Language : 2</p> <p>Operating mode : 3</p>	<p>-----Basic--settings-----</p> <p>Language : 2</p> <p>Operating mode : 3</p>



"FUN" button for 2 sec. And hold to exit the base.

In the "Multi" accepts the MAR or MARH- controller pump control. For this purpose, all MARE and MARI controller via Modbus with the MAR / H controllers are connected. On MARE-EP66 each slave number must be set. He must be no gaps between the slave number. There must be no double assignment of the slave numbers.

Status memory

Starts:	15
RH:	000 : 00 : 43



Status displays in multi mode operation
Example double system with MARH

<p>-----</p> <h2>Station 1</h2> <p>AUTO P1: 42Hz 007,9A</p>	<p>-----</p> <h2>Station 2</h2> <p>AUTO P2: 00Hz 000,0A</p>	<p>-----</p> <h2>Station 3</h2> <p>AUTO P2: 00Hz 000,0A</p>	▲ ▼
-------------------------------------------------------------	-------------------------------------------------------------	-------------------------------------------------------------	-----

Multi set parameters

---Multi-mode--Parameter---	
Slave	: 1
emergency mode	: 1
distress frequency	: 40,0



11.1 Multi parameter Setting the example of the slave address.

▲ ▼	SET	▲ ▼	SET
-Multi-mode--Parameter- Slave _____ : 1 emergency mode : 1 distress frequency :40,0	-Multi-mode--Parameter- Slave _____ : 1 emergency mode : 1 distress frequency :40,0	-Multi-mode--Parameter- Slave _____ : 2 emergency mode : 1 distress frequency :40,0	-Multi-mode--Parameter- Slave _____ : 2 emergency mode : 1 distress frequency :40,0

11.2 Setting multi mode parameters

Enter the slave address for the multi-operation. Attention! Only use each address once

Slave Number :1 - 1 - 6 (MARH Address: 101- 106) 1 - 4 (MAR)

Enter the function for emergency operation. 1 = Off, 2 = distress frequency code, 3 = distress frequency with autostart.

emergency mode :1 - 1 - 5

Enter the distress frequency of the pump. This function gives you the possibility the pump with distress frequency to operate if the main controller.

distress frequency :40Hz - 1Hz - 200Hz

11.3 Construction scheme of a multi-pump system with 4x EM30 + MARH Controller

- Slave Number** :1 (MARH Address: 101- 106)
- Slave Number** :2 (MARH Address: 101- 106)
- Slave Number** :3 (MARH Address: 101- 106)
- Slave Number** :4 (MARH Address: 101- 106)

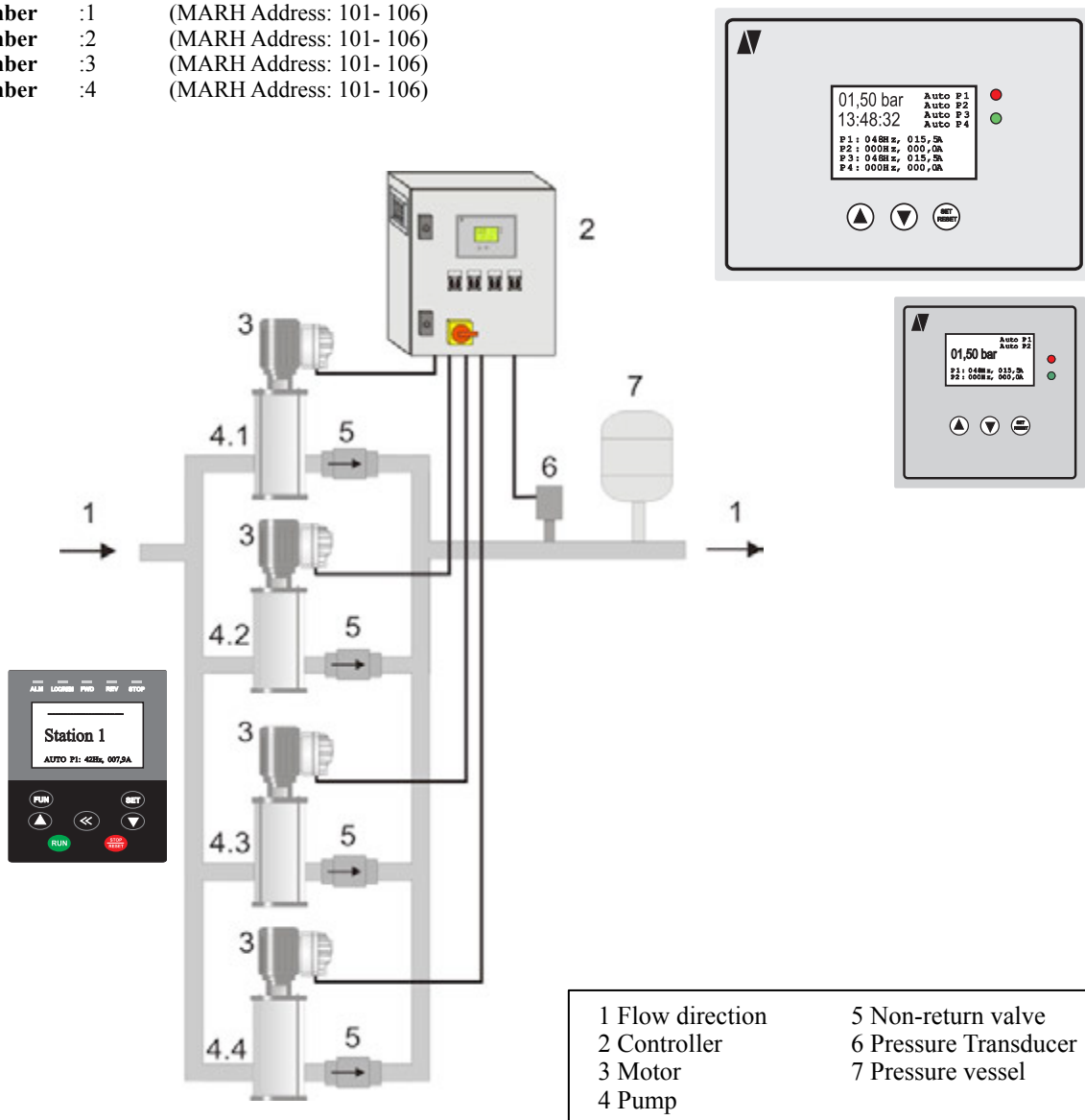

12. Operating mode "frequency"(4) **CODE Input!** **Attention ! Only in stop possible!**



Press "Stop" button.



"FUN" button for 10 seconds. hold

The basic menu is displayed.

basic settings

▲ ▼ SET ▲ ▼ SET

-----Basic--settings----- Language : 0 Operating mode : 1	-----Basic--settings----- Language : 0 Operating mode : 1	-----Basic--settings----- Language : 0 Operating mode : 4	-----Basic--settings----- Language : 0 Operating mode : 4
-----------------------------------------------------------------	-----------------------------------------------------------------	-----------------------------------------------------------------	-----------------------------------------------------------------



"FUN" button for 2 sec. And hold to exit the base.

Controller Menu (1)

Chain Menu (2)

Multi Operation menu (3)

frequency menu (4)

-Controller--Parameter-- -----	-----Chain--Parameter-- -----	-----Multi--Parameter-- -----	-----Inverter----- -----
-----------------------------------	----------------------------------	----------------------------------	-----------------------------

Status displays in FU operation

Example Stop mode or Run mode

-----Inverter----- 00,0 Hz 000,0 A STOP	-----Inverter----- 35,0 Hz 007,2 A RUN
----------------------------------------------------------	---------------------------------------------------------

FUN ▼

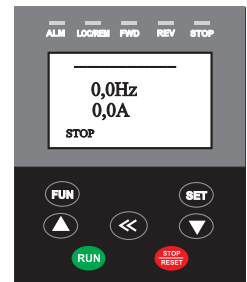

Parameter menu

-----Inverter-----

F114 : 10,0

▲ ▼

12.2 Setting parameters in operating frequency

▲ ▼ SET << (if necessary) ▲ ▼

-----Inverter----- F114 : 10,0	-----Inverter----- F114 : 10,0	-----Inverter----- F114 : 10,0	-----Inverter----- F114 : 12,0
-----------------------------------	-----------------------------------	-----------------------------------	-----------------------------------

SET ▲ ▼ << (if necessary) ▲ ▼

-----Inverter----- F114 : 12,0	-----Inverter----- F115 : 10,0	-----Inverter----- F115 : 10,0	-----Inverter----- F125 : 30,0
-----------------------------------	-----------------------------------	-----------------------------------	-----------------------------------

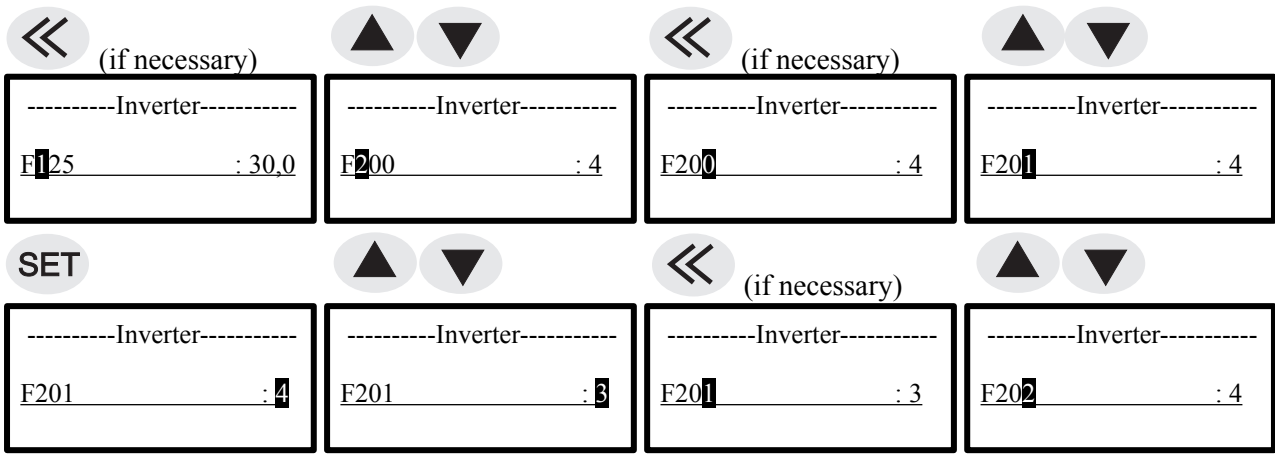

12.3 Setting the frequency parameter

Enter the value of parameter F 114. F114 = ramp (Example)
F114 :10.0 - 0.01- 99.0

All other parameters can be found in the original operating instructions of the frequency inverter!

13. Adjust motor characteristic

13.1 Set PM synchronous motor

If the characteristic is set to "6", the motor data are opened in the menu. These must be entered exactly. After the input has been completed, the "calibration" must be carried out.

-----Basic--settings-----	

Characteristics	: 6
Motor power	: 5,5
Motor voltage	: 400
Motor current	: 10,5
Motor speed	: 3000
Motor frequency	: 100
calibrating	: 0



Warning !

These inputs are important to ensure optimum operation of the motor!



Caution !

These inputs are important in order to avoid motor damage!

Set the characteristic for the motor. When "6" is selected, the motor data must be entered.

Characteristics :6 - 2 = V/Hz- Asynchronous motor, 6 = PM- Synchronous motor

Enter the motor power. Data: See type plate.

Motor power :xxx,xkW - 0,01s - 199,9kW

Enter the motor voltage. Data: See type plate.

Motor voltage :xxxV - 1V - 500V

Enter the motor current. Data: See type plate.

Motor current :xxx,xA - 0,01A - 199,9A

Enter the motor speed. Data: See type plate.

Motor speed :3000n - 100n - 9999n

Enter the rated motor frequency. Data: See type plate.

Motor frequency :xxxHz - 1Hz - 200Hz

SET

Set "Measure" to "2" and then press the "Set" button.

The "calibration" is now carried out. This process takes some time.

After successful calibration, the "calibrating" parameter is reset to "0".

calibrating :0 - 0 = calibrating off, 2 = calibrating on

END Menu

14. Clear fault memory / Starts

14.1 Code Input



Access control is to make even for the basic setup for the menu.
Is "locks" a lock is fully set on the display.
If "Lock" part set is the "motor potentiometer" freely accessible.
For the basic setting or for the menu of the code must be entered.

14.2 Read / Clear fault memory

Error memory

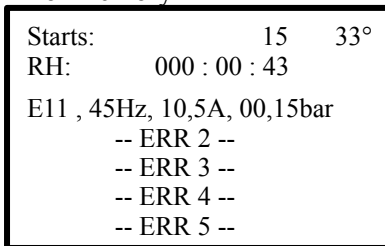

SET "Set" button and hold for 60 sec. to clear the fault memory.

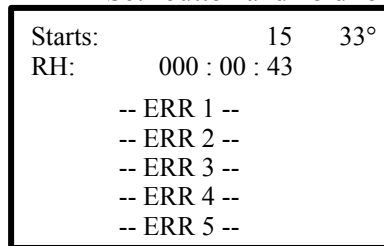

14.3 Start side

The control is initialised when the device is switched on. This process takes a little.
This display is displayed when "Power On". The serial number is then readable.

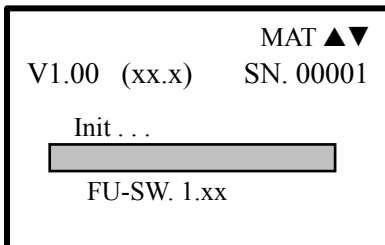

15. Status of the LED indicators on the MARI Display

	ALM	LOC/REM	FWD	REV	STOP
ALM	=	Alarm (fault)			permanent light
ALM	=	Alarm (Guardian)			flash light
LOC	=	Control mode (local)			permanent light
REM	=	Multi mode (remote)			flash light
FWD	=	Clockwise (forward)			permanent light
REV	=	Anticlockwise (reverse)			permanent light
FWD	=	forward (Standby)			flash light
REV	=	reverse (Standby)			flash light
STOP	=	Stop			permanent light
STOP	=	Standby / External off			flash light

16. Connection diagram MARI version 400V - 1.12 and higher

Power supply:

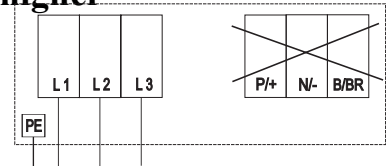

Attention ! Only connect terminals L1 / L2 / L3 and PE!

Sensor adjustment on the sliding switch block: see version
 GND - CM = Always connect the 0V potentials!

Position Gr1. 0.75-4kW

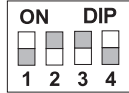

Gr. 2 5.5-7.5kW

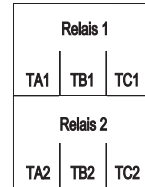
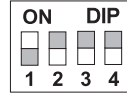

Connect relay 1/2:

TA1 = NO contact TB1 = NC contact TC1 = Reference (alarm)
 TA2 = NO contact TB2 = NC contact TC2 = Reference (running signal)

Connecting Modbus: set the operating mode "Multi" in the basic menu

GND = 0V potential MAR / I master (GND)
 A + = MAR / I master (A +)
 B - = MAR / I master (B-)

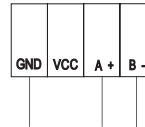

Connect sensor:

4-20mA = 24V = + supply 24V = + supply
 AI2 = 4-20mA signal input CM = supply
 0-10V = AI1 = 0-10V signal input

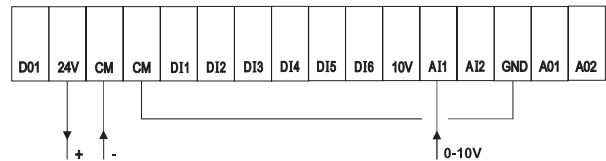
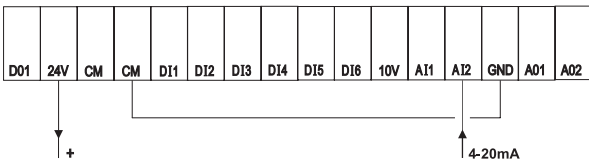

Connect the PTC thermistor to the MARI-EM 30:
 CM = PTC connection DI5 = PTC connection

Activate PTC in the basic menu

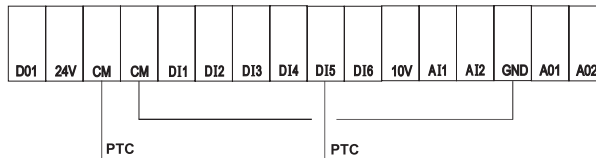

Connect the chain with two MARI-EM30: set the operating mode "chain" in the basic menu
 FU1-DO1> FU2-DI1 FU2-DO1> FU1-DI1 FU1-CM <> FU2-CM

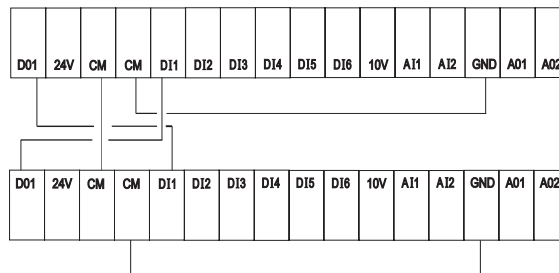

Connect input Ext.1 / 2 to the MARI-EM 30: Set Ext1 / 2 in the controller menu

CM = reference connection DI1 = Ext.1 Connection normally open (on / off)
 CM = reference connection DI2 = Ext.2 Connection NO (alarm)

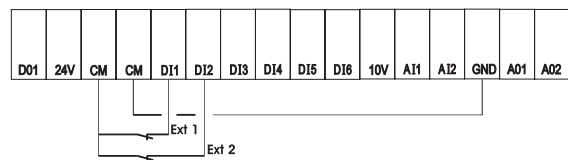
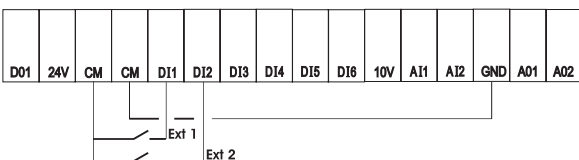

17. Customer settings MARI :

Date: _____

EURA Drives GmbH

Mühlenweg 143
22844 Norderstedt (Germany)

Tel.: +49 40 589 7950 0
Fax.: +49 40 589 7950 29

www.euradrives.eu